

**REGULATIONS OF GEOMATICS  
(WORK INSTRUCTIONS)  
PART II (GEODETIC)**

**SURVEY DEPARTMENT  
MINISTRY OF DEVELOPMENT  
BRUNEI DARUSSALAM**

## PART II – GEODETIC

### 1. TYPES OF SURVEYS

This Instruction is applicable to the following work of:

1. Terrestrial geodetic control survey
  - a. Traversing
    - i. First Class
  - b. Levelling
    - i. Precise Levelling
    - ii. Ordinary Levelling
2. GNSS (Global Navigation Satellite System) is a satellite system that is used to pinpoint the geographic location of a user's receiver anywhere in the world applicable for geodetic control survey and Cadastral Measurement portion of a Cadastral Survey. This can be apply as:
  - a. Static GPS Surveying
  - b. Rapid Static GPS Surveying
  - c. Differential GPS (DGPS)
  - d. Real time kinematic (RTK) GPS Survey

### 2. GNSS (GLOBAL NAVIGATION SATELLITE SYSTEM)

#### 2.1 GNSS components:

##### 2.1.1 Mission Planning And Reconnaissance:

Satellite signals were introduced as the measurable quantities that are needed to generate monitoring information. Satellite signals are microwaves that penetrate cloud cover and travel under all weather conditions, but unfortunately cannot penetrate dense vegetation, canopies or buildings. Because of this, and in order to reduce the detrimental effects of atmospheric refraction and multipath signals, it is desirable that **the antenna has as clear view of the sky as possible.**

An **elevation angle of above 15°** is often considered suitable to enable a clear sky view though this could at times be **as low as 10°**.

Some antennas are equipped with a groundplane which block unwanted multipath signals from reaching the antenna. Nearby metallic objects, such as fences and power lines, should be avoided where possible in order to prevent imaging, i.e., when metallic objects act as secondary antennas, thereby distorting the positions derived from GNSS satellites. It is therefore recommended that the GNSS observation sites be selected in open areas away from potential sources of multipath and imaging where possible.

**PDOP** is computed from the positions of the satellites in relation to the receiver and takes a single value, It is a measure based solely on the geometry of the satellites and therefore can be computed prior to any observation being taken.

A higher PDOP value (i.e., >6) will indicate a worse satellite geometry for computing a position. In mission planning therefore, PDOP values are computed and used to indicate the observation window where the satellite constellation is good. PDOP less than 4 is considered the best for GPS observation.

In order to decide on the appropriate time to carry out GNSS observations, any mission planning software such as those of Sokkia or Trimble could be used. Most receivers will come with software which is capable of conducting mission planning that can be used to indicate the position of the satellites during the desired observation time. The software provides DOPs which are useful in indicating the geometrical strength of the satellite constellation

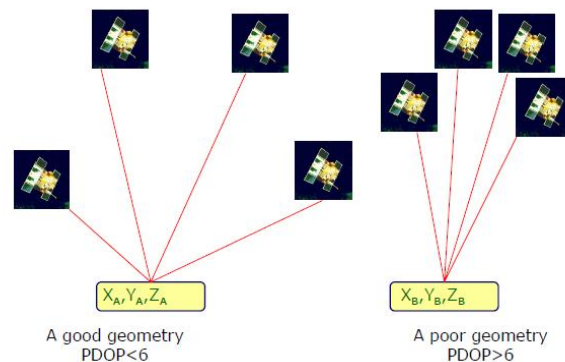

Figure 1 - DOPs Geometry

### 2.1.2 The basic stages for planning a GNSS survey are generally as follows:

1. Locate unknown control points and update reference mark information if necessary.
2. Assess the suitability of unknown control points for GNSS positioning and check for multipath sources in the vicinity.
3. If necessary, construct a visibility diagram using a compass and a clinometer. The compass will provide an approximate position from the true North, while the clinometer will give the elevation of features such as buildings and vegetation. This will indicate the satellites likely to be blocked by tall buildings and trees. Such a diagram should also contain information on potential multipath sources.
4. Locate local reference stations. This will provide baseline positioning information.
5. Assess the suitability of these reference stations for satellite surveying and check for multipath sources in the vicinity.

Several planning parameters are available:

1. Sky Visibility – The Sky Plot
2. Satellite Constellation
3. Dilution of Precision

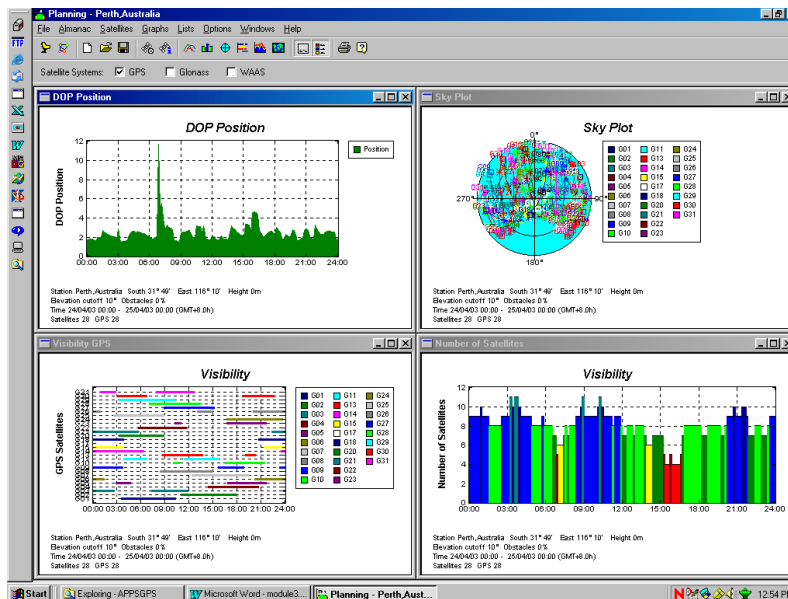

Figure 2- Planning Parameters-Trimble Business Center software

## 2.2 FIELD PROCEDURE

Having done the planning, the next step involves the actual procedure for the field measurements. The objective of a given environmental task will dictate the types of equipment needed for the task. If the objectives require more precise and accurate work, e.g., monitoring rise in sea level, then the correct receivers and field procedure must be adopted.

One of the tasks undertaken during a GNSS survey is the setting up of the antenna over some mark. These marks can be made of pillars upon which the GNSS receiver is set or some marks on the ground, in which a tripod has to be used.

*In older equipment, the receivers and antennas were separate components but modern equipment such as Sokkia incorporate both receivers and antennas as one unit.*

Setting the antenna over the mark should be done as accurately as possible in order to reduce centering errors. The receiver must be levelled, aligned over each point, and the height of its geometrical center above the point recorded. Antenna heights are normally measured to **the phase center**. Sometimes, this phase center does not coincide with the geometrical center of the antenna leading to what is called **antenna phase center** variation. In high precision satellite measurements, this phase center variation can lead to errors in the range of millimeters to a centimeter. Most precise (geodetic) receivers possess antenna phase center models which can reduce this effect during the post-processing of the measurements.

In **relative positioning**, the error due to phase center variation can be eliminated through the matching of the antennas by aligning both to North.

The most common source of error during the setting up of the antenna is incorrect measurement of the antenna height. Since GNSS provides three-dimensional positions, any error in height determination will propagate to contaminate the lateral position, and vice versa.

As a **standard practise**, comprehensive field notes should be kept, which should include the station and surveyor's name, start and end times of the survey, type of receivers and antennae used, data file names, satellites used, details of reference marks, potential sources of errors and obstructions and **most importantly, the antenna height.** (stated at **GDC007-GNSS OBSERVATION LOG SHEET**)

### 2.2.1 ABSOLUTE GPS POSITIONING

The use of precise post-processed satellite orbits and satellite clock corrections in absolute positioning, using **one GPS receiver only**, has proven to be an accurate alternative to the more commonly used differential techniques for many applications.

The absolute approach is capable of centimeter accuracy when using state-of-the-art, dual-frequency GPS receivers. When using observations from dual-frequency receivers, however, the accuracy, especially in height, increases. The observation shall be more than 2 to 3 hours for > 70 km in order to have a best baseline tied with zero-order GPS base station (CORS) for post processing.

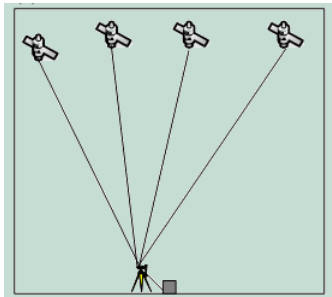

Figure 3-Absolute GPS positioning

### 2.2.2 RELATIVE GPS POSITIONING

Differential or relative positioning requires at least **two receivers set up at two stations** (usually one is known) to collect satellite data simultaneously in order to determine coordinate differences. This method will position the two stations relative to each other (hence the term “relative positioning”) and can provide the accuracies required for basic land surveying

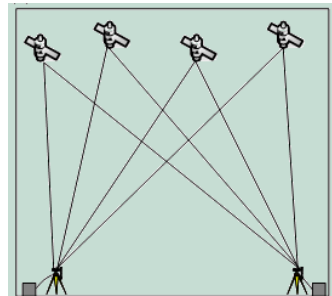

Figure 4-Relative GPS positioning

## 2.3 TYPES OF GNSS SURVEY:

### 2.3.1 STATIC GPS SURVEY

Where a reference station exists, the static relative positioning is recommended for higher positioning accuracy. In this mode of operation, two GNSS receivers or more are required in order to observe the same satellites simultaneously. Though additional cost is incurred in providing additional equipment, the

advantage over absolute point positioning is the capability of eliminating or minimizing errors associated with the atmosphere and satellite orbits through differencing techniques.

This method is more effective over short baselines of less than 20km where the atmospheric errors are assumed to be the same. Using this method, one receiver will be set at a reference (control) station while the other receiver will be set at an unknown station. Tracking of satellites must then be simultaneous and synchronized (i.e. same time and instant). The observation time takes **1 hour or more** with data being sampled at **intervals of 10-15** seconds. The times of observation is depend on location and surround environment of the areas.

Longer duration of observation benefits from the improved satellite geometry leading to better solution of the unknown integer ambiguities. When the settings are properly done, and errors minimized through proper prior planning, the method is capable of giving coordinate differences ( $\Delta X; \Delta Y; \Delta Z$ ) of centimeter to millimeter accuracy. This method is useful in establishing of higher precision control networks.

***This GPS methodology is most used for Geodetic Surveying as a control marks. These GPS survey can be applied using Absolute GPS Positioning or Relative GPS Positioning.***

### **2.3.2 STATIC RAPID GPS SURVEY**

Rapid GNSS positioning using carrier phase pseudorange includes techniques such as rapid static or fast static survey, stop-and-go survey, and kinematic survey. Rapid or fast static survey are usually post-processed while stop-and-go and kinematic survey can be used in post-processing or in real-time modes of operation. Whereas for Static Surveying ambiguity is resolved through long term averaging and simple geometric calibration principal resulting in solution of linear equation that produces a resultant position.

Rapid-static or fast-static survey is essentially the same as static survey, but makes use of shorter station occupation times. In this approach, one or more roving GPS receivers occupy all unknown stations or at least one receiver (reference station) is stationary at a known control station all the time.

The rapid nature of this type of survey compared to static survey is due to the rapid solution of the integer ambiguities, making use of all observable satellites, single or both dual-frequency L1/L2, and carrier phase data.

Although fast-static relative positioning is accurate and economical where there are many points to be surveyed and offers more efficient positioning than conventional Static Relative Positioning, the **accuracy is usually slightly lower at centimeter level,**

Due to the special processing algorithm used for solving the integer ambiguities, at least four satellites need to be tracked continuously. The technique is only effective over short (<10-20km) baselines and the observation occupation time depends on the number and geometry of the satellites visible.

Station occupations generally vary **between 10 and 30 minutes with a data sampling rate of 5 seconds per sample,** depending on the distance to the base as well as the satellite geometry

***This GPS methodology is much preferable for Cadastral Surveying as a control marks for its traverse. This GPS survey can be applied using the Absolute GPS Positioning or the Relative GPS Positioning. In addition, the control marks used shall be verified by GPS Unit Geodetic Section, Brunei Survey Department.***

### 2.3.3 DIFFERENTIAL GNSS (DGPS)

This procedure is theoretically identical to post-processed **Static Relative Positioning** using code pseudoranges, except that everything happens in real-time. The solutions using differential corrections and post-processed data both give identical results. Due to the fact that the user obtains realtime results, **in addition to the two receivers used in the case of static relative positioning, a real-time data link, e.g., radio or mobile is required.**

The purpose of the data link is to transmit the “range corrections” from the reference station to the roving receiver for it to correct its own measured pseudoranges based on corrections computed at the reference station.

In general, a DGPS system will comprise of the reference sites whose coordinates are already well known to a higher accuracy, having been already surveyed using GPS carrier phase; a receiver measuring code or carrier phase pseudo-ranges, computing and transmitting the corrections; and a data link for transmitting the differential corrections using different radio frequencies.

### 2.3.4 REAL-TIME KINEMATIC (RTK)

As the name suggests, this method is capable of delivering real-time positions in the field as the survey is being undertaken. It uses the DGPS principle. The base receiver remains stationary and has a transmitting radio link while the roving receiver is in motion and has a receiving radio link. The base receiver samples data every second and transmits these raw data together with its position via the communications link (e.g., satellites, mobiles or radio) to the roving receiver. Using its radio receiver, the rover receives the transmitted data from the base receiver and uses in-built software to combine and process the GNSS measurements obtained at both the base and

roving receivers to obtain its position. Normally the surveyor carries the roving receiver attached to the radio link in a back pack. The method requires the fixing of the integer ambiguities at the start of the survey (initialization) before undertaking the survey. Once the initial ambiguity has been fixed, the roving receiver can be moved. Any loss of-lock due to obstructions makes a re-initialization necessary.

**Notes:** *In order not to confuse real-time DGPS and RTK, it should be remembered that DGPS uses code pseudorange corrections improving the positioning accuracy from 15 m to 5 m, while RTK uses raw carrier phases and codes*

**Network RTK:** Since most RTK systems require the roving receiver to be within 10 km from the base station (assuming similar atmospheric conditions), use of multiple base stations, i.e. network RTK, provides an alternative for baselines more than 10 km long. Ambiguities must still be resolvable within seconds or instantaneously, up to baselines of 50-100 km in length, which requires the consideration of orbit, troposphere, and ionosphere errors.

## 2.4 GNSS GPS POSITIONING ACCURACY REQUIREMENT:

GPS applications are classified into three general categories:

**Class A (Scientific) : better than 1 ppm. (one part in  $10^6$ ,  $\frac{1}{1,000,000} \times 100\% = 0.0001\%$ )**

**Class B (Geodetic) : 1 to 10 ppm.**

**Class C (General Surveying) : lower than 10 ppm.**

Note: 1ppm - 1 millimeter per kilometer of distance

**Category A (Zero Order Network)** surveys primarily encompass those surveys undertaken for precise engineering, deformation analysis, and geodynamic applications.

**Category B (Primary Order Network)** surveys include geodetic surveys undertaken for the establishment, densification and maintenance of control networks to support mapping.

**Category C (Secondary Order Network)** surveys primarily encompass lower accuracy surveys, primarily undertaken for urban, cadastral, geophysical prospecting, GIS and other general purpose mapping applications.

**In general depending on position mode and measurement types used are listed below:**

| Methods                              | Accuracy (95%) Horizontal* | GPS Equipment                            | Application                               |
|--------------------------------------|----------------------------|--|---|
| Static GPS Surveying-(carrier phase) | mm-cm level                | Geodetic receiver and antenna            | GEODETIC (Class B)                        |
| Rapid Positioning Methods-(code)     | 0.5-1 m                    | Geodetic receiver and antenna            | GEODETIC (for checked)/CADASTRE (Class C) |
| Differential GPS (DGPS)              | 3-5 m                      | Geodetic receiver and antenna            | GEODETIC(for checked)/CADASTRE/ Mapping   |
| Real time kinematic (RTK) Surveying  | 10 cm                      | Geodetic receiver and antenna with radio | GEODETIC(for checked)/CADASTRE/ Mapping   |

## 2.5 STANDARDS OF CLASS AND ORDER

CLASS is a function of the planned and achieved precision of a survey network and is dependent upon the following components:

- the network design,
- the survey practices adopted,
- the equipment and instruments used, and
- the reduction techniques employed,

All of which are usually proven by the results of a successful, minimally constrained least squares network adjustment computed on the ellipsoid associated with the datum on which the observations were acquired.



The allocation of CLASS to a survey on the basis of the results of a successful minimally constrained least squares adjustment may generally be achieved by assessing whether the semi-major axis of each relative standard error ellipse or ellipsoid (ie one sigma), is less than or equal to the length of the maximum allowable semi-major axis (r) using the following formula:

$$r = c (d + 0.2)$$

Where

r = length of maximum allowable semi-major axis in mm.

c = an empirically derived factor represented by historically accepted precision for a particular standard of survey.

d = distance to any station in km.

The values of c assigned to various CLASSES of survey are shown in Table1:

**Table 1- Classification of Typical**

| <b>CLASS</b> | <b>C<br/>FOR ONE SIGMA)</b> | <b>Typical applications</b>                     |
|--------------|-----------------------------|---|
| 3A           | 1                           | Special high precision surveys (IGS)            |
| 2A           | 3                           | High precision National geodetic surveys (CORS) |
| A            | 7.5                         | Densification of geodetic survey (MONITORING)   |
| B            | 15                          | National geodetic surveys (PRIMARY)             |
| C            | 30                          | Survey coordination projects (SECONDARY)        |
| D            | 50                          | Lower CLASS projects                            |
| E            | 100                         | Lower CLASS projects                            |

## 2.6 ASSIGNING CLASS TO A SURVEY

### Example - Application of CLASS and ORDER

A network of survey observations, obtained using Class A instrumentation & techniques, is adjusted in a minimally constrained least squares process which satisfies the a posteriori statistical tests.

In the adjustment output, standard (1  $\sigma$ ) line error ellipses (relative ellipses) are generated between adjacent points in the network. The allowable limit for the assumed Class A is calculated for each of these lines and compared to the ellipse's semi-major axis

If all line error ellipses are less than or equal to their limit for the proposed Class, then hypothesis is true and the network may be adopted as Class A.

If all the line ellipses are greater than the limit for the proposed Class then the hypothesis is false and the network should be tested for a lower Class.

If most of the ellipses are less than the limit for the proposed Class, but a few are greater, then professional experience must be used to decide whether to downgrade the whole network, or just part of it, or to check and possibly re-observe parts of it.

E.g. for one line of a network, between points 1 and 2:

| From | To | Semi-Major axis | Distance | Class A allowable limit          |
|------|----|-----------------|----------|----------------------------------|
| 1    | 2  | 0.23 metres     | 33       | $7.5 (33+0.2) = 0.248 \text{ m}$ |

**As 0.23 < 0.248, the assumed Class A is valid for this part of the network**

## **2.7 CORS (CONTINUOUSLY OPERATING REFERENCE STATION)**

CORS station is a stationary GNSS receiver which is continually collecting data from visible GNSS satellites on a 24 hour basis in order to produce three dimensional coordinates of the respective stations. CORS networks vary in sizes ranging from national to global scales (e.g., the International Global Navigation Satellite System (GNSS) Service (IGS)). Each individual CORS station is positioned accurately using precise GNSS. CORS data support high-accuracy three-dimensional positioning activities.

For baseline processing or minimal constraint of GPS processing the continuous (base station) is mark as fix and roving(rover) is mark as float if 2 receivers is applied for the observation.

As for final adjustment or fully constraint of GPS processing for:

***GEODETIC (Class B) at least 2 CORS is required for adjustments and for CADASTRE (Class C) at least 2 CORS and 2 existing Geodetic Stations or new established Geodetic Stations is required for adjustments.***

## **2.8 DATA AVAILABILITY**

### **2.8.1 RINEX SHOP**

- The CORS data are available in RINEX 2.0 format.
- Data rate – Optional 1 - 60 sec.
- Data from the CORS are available in 24/7
- The operational status of the CORS will be available on its webserver-  
*<http://202.160.30.98/>*
- Data download is made through Internet FTP only and need to be subscribed
- In the absences of CORS, clients shall informed Geodetic Section Brunei Survey Department for manual download; as clients need to inform the days and times of the observation.

**If happen of persistant loss of CORS due to technical problem, the best alternative solution is to create one reference station as a control station which the GPS observation duration of 5 hours continuous is a must.**

The specification of **Static GPS Surveying** methodology must be followed in order to get the best accuracy and the GPS data will be processed using AUSPOS. The online GPS processing system is engined or scripted by scientific Bernese software applicable anywhere on earth, which is able to process long baseline using IGS station over the region.

**In order to use the AUSPOS the surveyors shall verify their GPS observation through GPS Unit, Geodetic Section Brunei Survey Department**

## 2.9 PROCESSING OF OBSERVATIONS

### Data processing generally proceeds in three steps:

1. The first step involves transferring the data from the GNSS receiver or data collection device to the computer for processing and archiving. Most commercial softwares are automated and have user interactive options for transferring the data. As we have seen already, there exist several types of GNSS receivers that can be used for data collection. With the full operational capability of most GNSS satellites, there will sure be more receivers on the market for civilian use.

These receivers normally come with their own commercial vendor processing software. For example, Trimble receivers come with the Trimble Geomatic Office (TGO) for processing the data, while Sokkia data are processed using Spectrum software. Where multiple receivers of different types are employed in a GNSS campaign, data from all these receivers should be first be transferred in a format that can be understood independent of the source receiver. This therefore calls for a receiver Independent data format. In satellite terms, this format is called RINEX, i.e., Receiver INdependent EXchange Format which can be automatically performed by the vendor software. For example, Trimble receivers will save GNSS data with an extension 'file.dat' while Sokkia receivers save their data with an extension file.PDC', both of which are in binary, which must then be converted to RINEX format, an ASCII (American Standard Code for Information Interchange) type of data before processing. Different processing software have different ways of converting receiver data into RINEX. Once the data are in RINEX format, they can then be processed using any software. Once the data has been transferred to a computer, the next step is preprocessing, which is dependent upon the type of the data collected, e.g., static or RTK, and the type of initialization.

2. **The Second step is preprocessing.** Once the data has been transferred to a computer, which is dependent upon the type of the data collected, e.g., static or RTK, and the type of initialization. Preprocessing consists of editing the data to ensure data quality, and determining the ephemeris, where one has to choose between broadcast and precise ephemeris when post processing baseline carrier phase observations. Autonomous hand-held receivers that use code measurements require no post-processed ephemerides, since this is automatically recorded during field operation. Editing activities done include the identification and elimination of cycle slips, editing gaps in information, and checking station names and antenna heights. In addition, elevation mask angles should be set during this phase, along with options to select tropospheric and ionospheric models

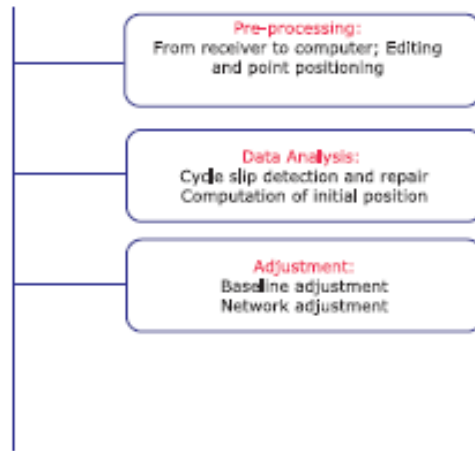

Figure 5- GPS processing key chart

**BASELINE PROCESSING :**

For single baselines, the processing deals with each baseline by baseline, or processes all the baselines through a joint adjustment. The final results depends on how well the ambiguities and other errors are tackled.

Commercial baseline reduction software have a variety of options that are automatically (or manually) set to determine the most "optimum" solution where after an initial code solution is performed, a triple differencing is performed followed by a double-differencing leading to a fixed solution in case the integer ambiguities are successfully resolved .

Correlations between the baselines are not necessarily taken into consideration except for network adjustment where they provide weight information .

If in GNSS satellites are observed,  $n(n-1)/2$  baselines will be adjusted with the double differencing offering the best solutions due to the fact that the integer nature of the ambiguities are preserved.

Most commercial software offers baseline processing capabilities and normally provide different solution types, e.g., L1 Fixed (only the L1 signal used to derive the solution), Ionospheric-Free Fixed (both L1 and L2 signals used to remove ionospheric errors and float but most software packages attempt to perform the most accurate fixed solution for short lines (e.g., less than 15 km for single-frequency and less than 30 km for dual-frequency receivers) . positioning accuracy will depend on how well the errors are managed. provides some accuracy insight from processing phase observations, while summarizes the data processing steps.

For baselines longer than 30 to 50 km, if the fixed solution is not deemed to be reliable (based on various quality indicators discussed below), then the default float solution may be used, which, although not as accurate as the fixed solution, if the session time is long enough (e.g., 1 to 2 hours), the float solution will be fairly accurate, e.g., 20 to 50 mm for lines less than 75 km. After the baseline solutions, users can then assess the reliability of the obtained solution from numerous statistical and graphical displays by the commercial software.

### **3.The third step is Quality Assessment Adjustment**

The output of data processing from most commercial software will often consist of position, covariance and residuals. Covariances are often provided in the dispersion matrix which enable the analysis of the quality of the estimated positions. The square roots of the diagonals of the dispersion matrices give the standard deviation. The dispersion matrix can also be used to construct error ellipses useful for the analysis of the estimates, and also to generate the dilution of precision.

Commercial software have set criteria upon which they base any decision to reject bad observations or output. The software compare solutions from triple,float, fixed, single baseline and multi-baseline to obtain the most optimum solution.

Adjustment only accepted baseline will be used in the network adjustment. No outliers in observations.

The following quality assessment factors upon which various software base their acceptance criteria are presented in greater detail such as:

- Variance ratio
- Root-mean-square (RMS)
- Accuracy
- Precision
- Standard deviation

Those quality assessment factors are much summarised at below statements.

#### **2.10 GEODETIC QUALITY ASSESSMENT FACTORS:**

1. 95% confidence level(Chi-Square test), less than or equal to 0.020 m for Northing and Easting components and 0.050 m (new marks) for height component.

#### **2.11 CADASTRE STATION(CONTROL PROJECT MARKS) QUALITY ASSESSMENT FACTORS:**

1. 95% confidence level, less than or equal to 0.030 m for Northing and Easting components and 0.070 m (new nail marks or Geodetic mark ) for height component.
2. Final coordinates shall be verified by JUK (GDK), Geodetic stations
3. Any control project marks done by LLS shall be submitted to SD and verified before site surveying done.

**Notes: If new Geodetic Stations is established a Static GPS Survey need to be applied and a standard proper marks verified by Geodetic Section need to be created as shown at figure below:**

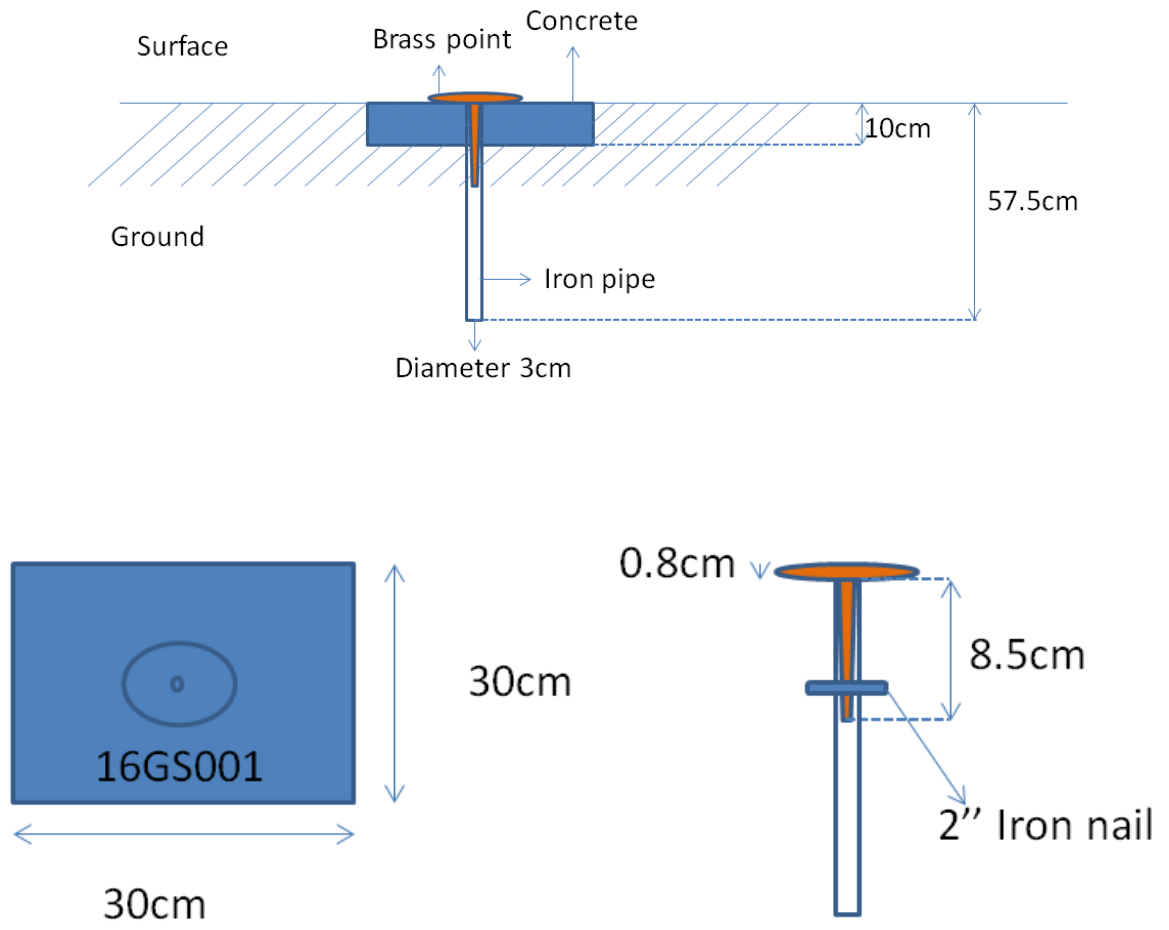

Figure 6- Geodetic mark

## 2.12 FINAL CHECKED OF COORDINATES

The differences of established Geodetic Stations and latest observations in the adjustment shall not exceed the tolerances of , less than or equal to 0.020 m for Northing and Easting components and 0.050 m (Geodetic mark ) for height component.

## **2.14 GNSS GPS Equipment Testing**

Equipment testing is required in order to ensure that they are in operational condition.

Universal GNSS splitter shall be used in order to do the testing. Also the splitter must be compatible with any GNSS brand.

### **2.14.1 ZERO BASELINE TEST**

The GNSS receiver used must be subjected to zero baseline test at yearly interval or after service and maintenance. The northing, easting and the height components of the zero-baseline should all be less than 3 mm.

### **2.14.2 SHORT BASELINE TEST**

A short baseline test is to be adopted for GNSS receivers and antennae at yearly interval or after service and maintenance. The mean differences in distances between established pillars and observed must be < 10 mm; observation must be 20 minutes each set.

**Original form GPS-GDC025 results of the test shall be approved by Surveyor General for certification.**

### **2.14.3 TRIBRACHS TEST**

The Tribachs or Plummet Test test shall be performed together with Zero baseline test and GNSS short baseline test.

**In order to get an approval of GPS calibration certification by Surveyor General; The GPS set need to pass Tribrach Test and either one Zero Baseline Test or GNSS GPS Short Baseline also need to be pass.**

## 3.0 TRAVERSES

### 3.1 GENERAL

Control points shall be surveyed using GNSS. First Class Traversing shall be carried out only in case of any obstructions or difficulties to carry out GNSS observation.

First Class traverse shall be run between existing GS marks and first class marks. Proposed traverses shall be approved by the SG. First class traverse shall be numbered by the year of survey (last two digits) followed by the letter 'FC' (First Class) and the three digits sequential number, Example : 07FC001, 07FC550, 07FC999. The distance between First Class marks and GS marks shall be within the range of 100 m to 500 m. The maximum length of a traverse shall be 5 km.

All precise level benchmarks along the route shall be coordinated.

### 3.2 ORIGIN AND CLOSING LINES

Observing to a third mark shall test the reliability of the origin and closing lines.

Where the origin or closing lines is between standards or first class marks at least one line shall be re-measured and the difference shall not exceed  $\pm(20 \text{ mm} + 50 \text{ p.p.m})$ .

### 3.3 OBSERVATIONS TECHNIQUE

A theodolite or total station reading to at least 1" of arc shall be used. Generally forced centering targets shall be used.

Four sets of horizontal and vertical readings shall be observed at each station. The initial circle settings for each set shall be as follows:-

| SET                               | CIRCLE SETTING |
|-----------------------------------|----------------|
| 1                                 | 0°             |
| 2                                 | 30°            |
| 3                                 | 60°            |
| 4                                 | 90°            |
| <b>The Residual not exceed 5"</b> |                |

### 3.4 BEARING CLOSURES

This shall not exceed  $8\sqrt{n}$  seconds for any traverse of n station and in any case shall not exceed thirty seconds. Check bearings shall be observed at every fifteenth station.



### **3.5 DISTANCE MEASUREMENT**

Distance shall be measured with calibrated electromagnetic equipment or total station capable of any accuracy of  $\pm (10 \text{ mm} + 10 \text{ p.p.m})$ . The horizontal and vertical distances on instruments, which read these directly, need only be recorded

### **3.6 TRAVERSE ADJUSTMENT**

The Geodetic Section of Survey Department shall carry out computation and adjustment. The field surveyor shall carry out preliminary closures to ensure that traverse closes are within 1:10 000. The computation of final co-ordinates shall be adjusted with the least square adjustment method

The traverse final calculation shall be computed using a Least Square Adjustment such as either GeoLab or Starnet softwares which is applicable.

# 4.0 LEVELLING

## 4.1 GENERAL

### 4.1.1 DATUM

All heights observed shall be reduced to Brunei State Datum 1988 (BSD88), which is Mean Sea level.

### 4.1.2 BENCHMARKS

Benchmarks shall be of the following types:

1. *Fundamental Benchmarks* placed at intervals of approximately 50 km or at major route junctions. They shall be carefully located on solid ground, preferably rock, where no local subsidence is likely.

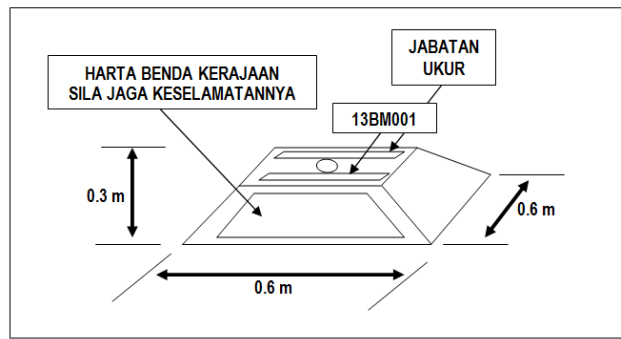
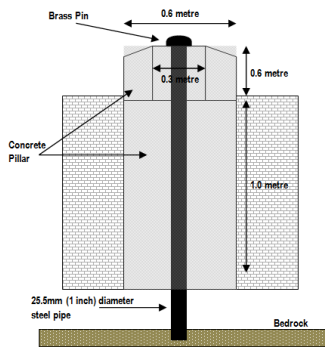

CONCRETE PILLAR COMPOSITION

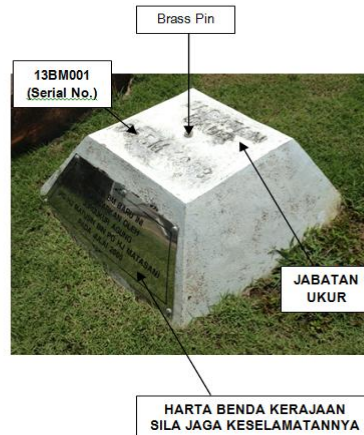
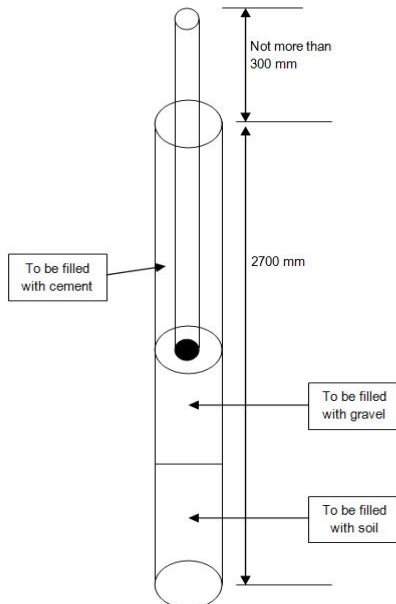

2. *Standard Benchmarks* are located along main roads at approximately 1.5 km intervals but it may vary due to suitability of the area. They should be located on stable ground and clear of likely roadwork

3. *Intermediate benchmarks* are located between standard benchmarks on suitable substantial structures such as bridge abutments or building foundations. Any establishment of Intermediate Marks shall be approved by Surveyor General

## **4.2 PRECISE LEVELLING**

### **4.2.1 GENERAL SPECIFICATION**

Precise levelling shall begin and end on previously established benchmarks. All lines are to be levelled independently in both forward and backward directions. In order that the results of the control levelling may be as widely useful as possible, particularly in regard to mapping, the elevation of suitable points adjacent to the level line will be determined. These points, which are to be known as Intermediate Marks will normally be intersections, decks of bridges, etc.

### **4.2.2 OBSERVATION PROCEDURE**

The backsights and foresights shall be approximately of the same length. The maximum length of sight shall not be more than 40 meter. Due to the slope of the ground or to shimmer the length of sight may often be shorter than this. Total distances of works is normally 1.5km but it may varies due to suitability of the area.

Two backward and two foresight observations shall be taken. Differences between observations shall not exceed 0.04572 cm. The difference in length between backsight and corresponding foresight shall not exceed 1.2 meter.

Acceptable precise levelling Invar staff shall be used or automated invar staff.

The staff is to be set always on a stave set up pin. These pins are different length for hard and soft ground and have rounded tops. A ring is attached to the pin to facilitate lifting and carrying. The stave shall be erected vertically by using plate bubble attached on the stave.

Observation of new benchmarks shall only be taken at least after **one week** of their construction. If the work is stopped on other than permanent benchmark, at least two temporary Benchmarks are to be established. On resuming work the marks must be checked for disturbance or change of relative height.

Observation shall be recorded digitally. As a checking procedure, the digitally recorded observation shall be printed out and submitted to Survey department

Read out from the instrument shall be set to five (5) decimal places. The minimum stave reading shall not be less than 0.5 meter. Clear diagrams shall be drawn digitally in a GDC001 form, sufficient offset or ties to permanent features nearest from benchmark for future location.

It is essential that all record /data are made in the field note at the time of measurement Digital photo of the station shall be included in the GDC001 form.

### **4.2.3 MISCLOSURE**

Height closes within an allowable error of  $\pm 3 \sqrt{k}$  mm where k is the distance in kilometre.

The final calculation shall be computed using a Least Square Adjustment (Difference Height Between BMs) such as either GeoLab, Trimble Business Center or Starnet softwares which is applicable.

## **4.3 ORDINARY LEVELLING**

### **4.3.1 GENERAL SPECIFICATION**

Ordinary levelling shall begin and end on previously established benchmarks or existing height control marks. Every levelling job shall be arranged in such a way that it can be checked and the amount of error established. The methods are:

Levels from a known benchmark or height control mark and check back on the same point. The total of backsights shall equal the total of foresights, and then the total rises and falls and first and last reduced levels shall be the same. Level from a known benchmark or height control mark and finish on another benchmark or height control mark.

The difference between the totals of backsights and foresights, between the totals of rises and falls, and between first and last reduced levels, shall be all be the same as the known difference between bench mark levels.

For checking purposes, all observation shall be recorded in a field note produced by Survey Department

### **4.3.2 OBSERVATION PROCEDURE**

The backsights and foresights shall be approximately of the same length. The maximum length of sight shall be 100 metre and the minimum length shall not less than 25 meter. Due to the slope of the ground or to shimmer the length of sight may often be shorter than this. Total distances of works shall not exceed 1.5km.

All observation shall be recorded digitally. As a checking procedure, the digitally recorded observation shall be printed out and submitted to Survey Department. Read out from the instrument shall be set to four (4) decimal places. The minimum stave reading shall not be less than 0.5 metre.

Clear diagrams shall be drawn digitally in a GDC01 form, sufficient offset or ties to permanent features nearest from any survey marks for future location. It is essential that all record /data are made in the field note at the time of measurement. Digital photo of the station shall be included in the GDC01 form

### **4.3.3 MISCLOSURE.**

Height closes within an allowable error of  $\pm 25 \sqrt{k}$  mm where k is the distance in kilometre.

The final calculation shall be computed using a Least Square Adjustment (Difference Height Between BMs) such as either GeoLab, Trimble Business Center or Starnet softwares which is applicable.

#### 4.4 NETWORK ADJUSTMENT

The Geodetic Section of Survey Department will verify precise and ordinary level networks and provide data (height) and Bench Mark location diagram on official lists

#### 4.5 TWO PEG TEST

**Two peg test** shall be performed at the field before doing any levelling tasks and the tolerance between two sights shall be  $\pm 0.020$  m

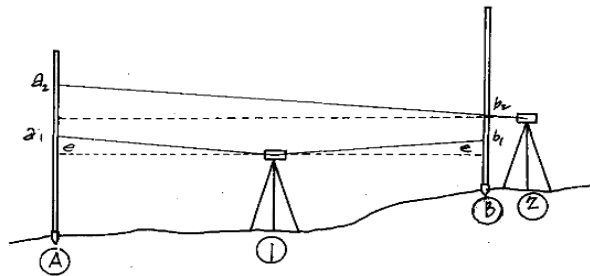

##### Example

Suppose the level were set up midway between A and B and the following readings were made

$$\begin{array}{rcl} a_1 & = & 1.720 \\ b_1 & = & 1.842 \\ \hline a_1 - b_1 & = & -0.122 \end{array}$$

The level is moved adjacent to B and the reading at  $b_2$  is 1.500

$$\begin{array}{rcl} \text{Now, } a_1 - b_1 & = & -0.122 \\ + b_2 & = & +1.500 \\ \hline a_2 \text{ should read} & = & 1.378 \end{array}$$

Figure 7-Sample of two peg test

#### 4.6 Report Submission and Data Format

Observer/ Surveyor is required to submit the GNSS survey/ Traversing/levelling report in hardcopy and softcopy to officer in charge.

- Submission of the **GNSS survey** shall include:
  1. GPS Observation Data- [RINEX format]
  2. GNSS Station Observation Log- (GNSS OBSERVATION LOG SHEET -GDC007)
  3. GNSS Baseline Processing Report
  4. Digital photograph of the control point in JPEG format (picture size – 800 X 600 pixels) in suitable position

- Submission of the **Traverse survey** shall include:
  1. Fieldbook
  2. Traversing logsheet
  3. Digital photograph of the control points
  
- Submission of the Levelling works shall include :
  1. Levelling report
  2. Digital photograph of BM
  3. Levelling logsheet